

30 January 2018, Photonics West 2018

Laser System Modeling with Fast Physical Optics

Site Zhang^{1,2}, Huiying Zhong^{1,2}, Christian Hellmann³, and Frank Wyrowski¹

¹ Applied Computational Optics Group, Friedrich Schiller University Jena, Germany

² LightTrans International UG, Jena, Germany

³ Wyrowski Photonics UG, Jena, Germany

Introduction

- Complexity in modern laser systems

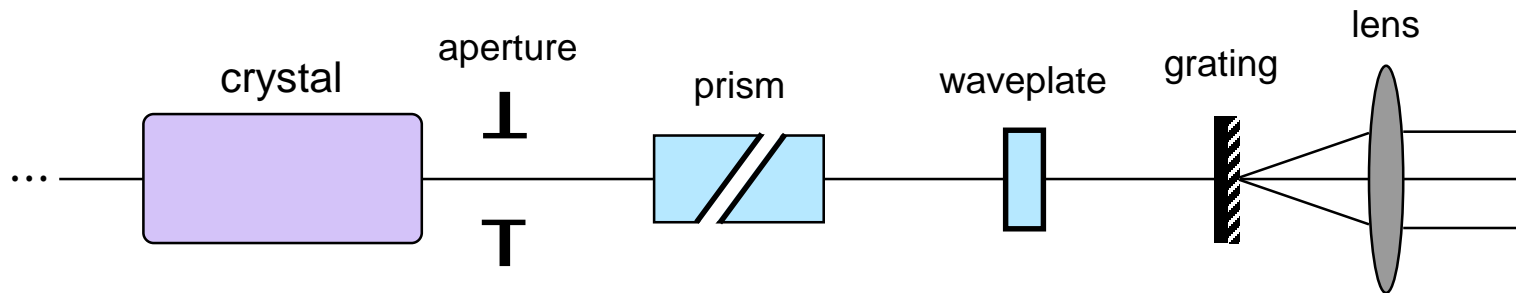

- Various types of components, with different feature sizes, integrated in one optical system

Introduction

- Complexity in modern laser systems

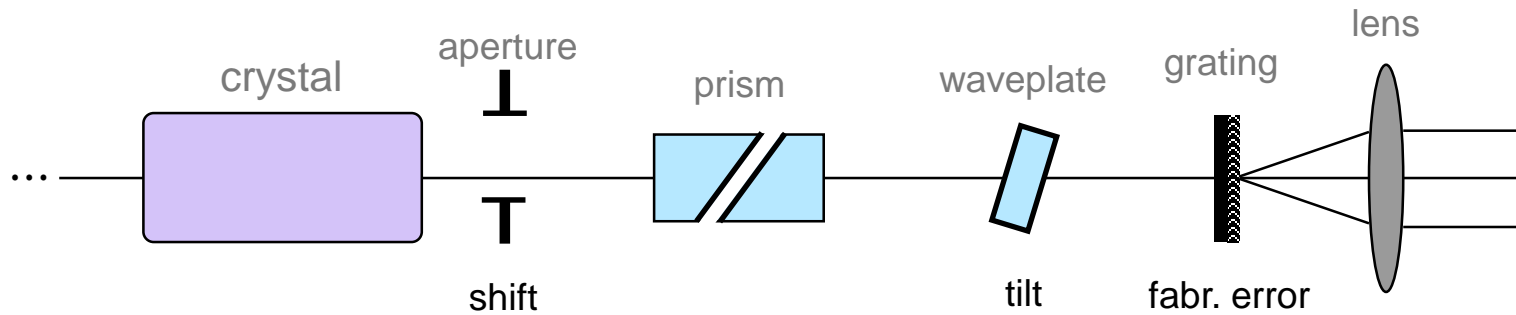

- Various types of components, with different feature sizes, integrated in one optical system
- Tolerancing of each component needs to be taken into consideration so to evaluate system performance

Introduction

- Complexity in modern laser systems



- Various types of components, with different feature sizes, integrated in one optical system
- Tolerancing of each component needs to be taken into consideration so to evaluate system performance
- Interaction with packaging / thermal / environmental effects is of concern

Fast Physical Optics by Field Tracing

- In fast physical optics we comply with the following
 1. Tearing: decomposed the whole optical system into regions and specialized Maxwell solvers are applied locally

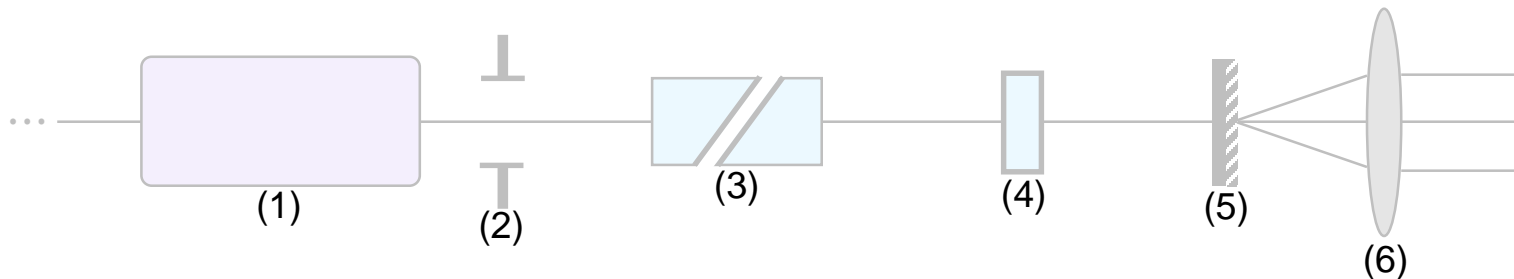
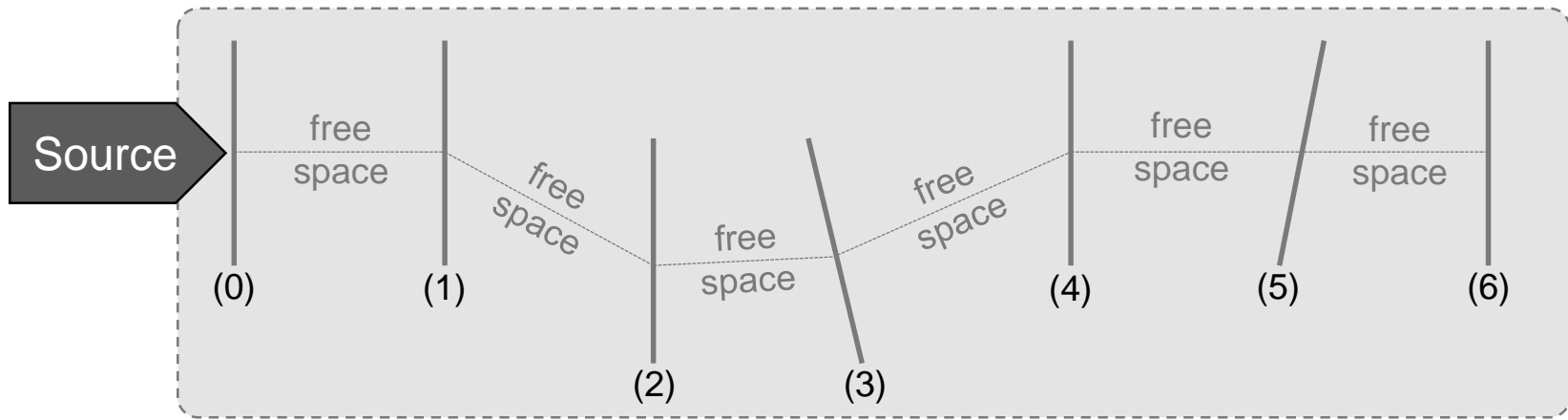

Fast Physical Optics by Field Tracing

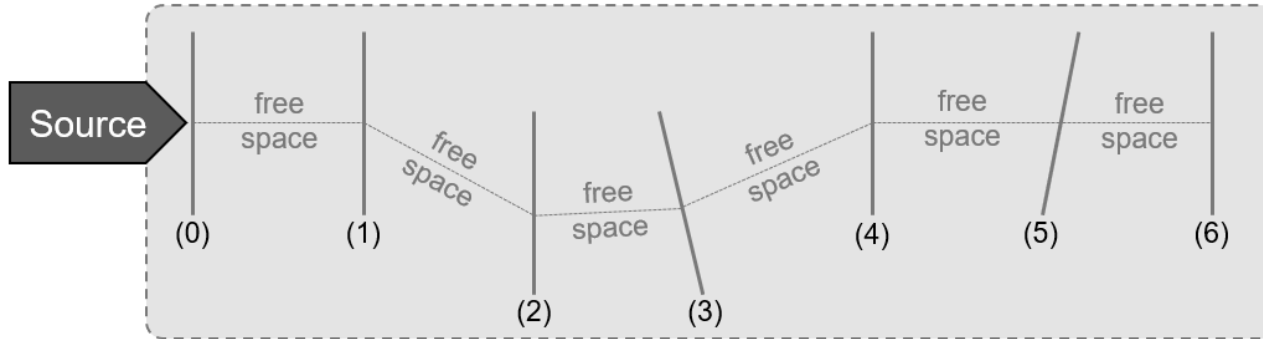

Propagation and component operators solve Maxwell's equations per region

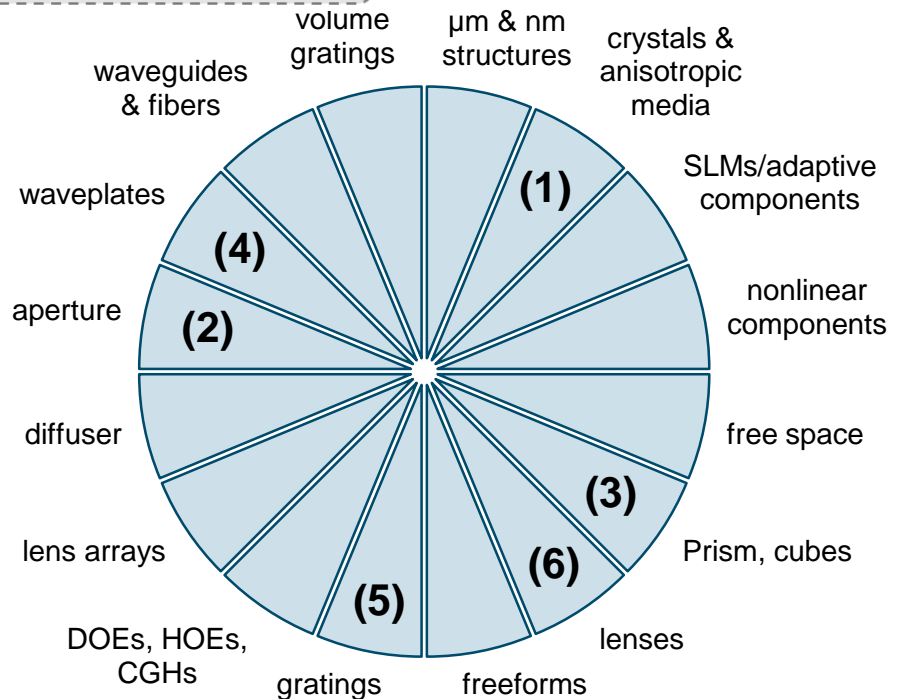

Fast Physical Optics by Field Tracing

- In fast physical optics we comply with the following
 1. Tearing: decomposed the whole optical system into regions and specialized Maxwell solvers are applied locally
 2. Interconnection: solutions in each regions are connected by the general non-sequential field tracing concept

Non-Sequential Optical Field Tracing

Michael Kuhn, Frank Wyrowski, and Christian Hellmann

Kuhn, M.; Wyrowski, F. & Hellmann, C. (2012), Non-sequential optical field tracing, *in* T. Apel & O. Steinbach, ed., 'Finite Element Methods and Applications', Springer-Verlag, Berlin, , pp. 257-274.

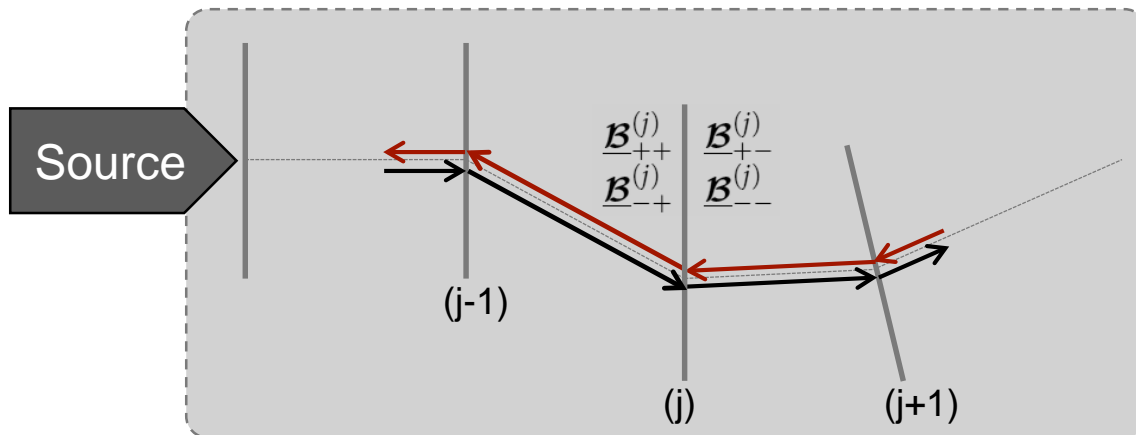

Visit our **Free Optical Design Seminar** on Feb. 02 and see more example regarding non-sequential field tracing

Fast Physical Optics by Field Tracing

- In fast physical optics we comply with the following
 1. Tearing: decomposed the whole optical system into regions and specialized Maxwell solvers are applied locally
 2. Interconnection: solutions in each regions are connected by the general non-sequential field tracing concept
 3. Field tracing operators should have numerical operation numbers linear with field sampling number N

Rigorous Propagation in Homogeneous Media

Maxwell's equations in x -domain:

$$\nabla \times \mathbf{E}(\mathbf{r}, \omega) = i\omega\mu_0\mathbf{H}(\mathbf{r}, \omega)$$

$$\nabla \times \mathbf{H}(\mathbf{r}, \omega) = -i\omega\epsilon_0\check{\epsilon}_r(\omega)\mathbf{E}(\mathbf{r}, \omega)$$

$$\nabla \cdot \mathbf{E}(\mathbf{r}, \omega) = 0$$

$$\nabla \cdot \mathbf{H}(\mathbf{r}, \omega) = 0$$

Integral operator is
a \mathcal{N}^2 operation!

Rigorous propagation in x -domain (Rayleigh-Sommerfeld integral):

$$V^{\text{out}}(\boldsymbol{\rho}, z) \propto \int \int_{-\infty}^{\infty} V^{\text{in}}(\boldsymbol{\rho}', z_0) \frac{\exp(ik_0\check{n}R)}{R} \left(ik_0\check{n} - \frac{1}{R} \right) \frac{\Delta z}{R} d^2\rho'$$

with $R = \sqrt{(x - x')^2 + (y - y')^2 + (\Delta z)^2}$.

Rigorous Propagation in Homogeneous Media

Maxwell's equations in x -domain:

$$\begin{aligned}\nabla \times \mathbf{E}(\mathbf{r}, \omega) &= i\omega\mu_0\mathbf{H}(\mathbf{r}, \omega) \\ \nabla \times \mathbf{H}(\mathbf{r}, \omega) &= -i\omega\epsilon_0\check{\epsilon}_r(\omega)\mathbf{E}(\mathbf{r}, \omega) \\ \nabla \cdot \mathbf{E}(\mathbf{r}, \omega) &= 0 \\ \nabla \cdot \mathbf{H}(\mathbf{r}, \omega) &= 0\end{aligned}$$

Maxwell's equations in k -domain:

$$\begin{aligned}\check{\mathbf{k}} \times \check{\mathbf{E}}(\boldsymbol{\kappa}, z, \omega) &= \omega\mu_0\check{\mathbf{H}}(\boldsymbol{\kappa}, z, \omega) \\ i\check{\mathbf{k}} \cdot \check{\mathbf{E}}(\boldsymbol{\kappa}, z, \omega) &= 0\end{aligned}$$

Simple product is
a N operation!

Rigorous propagation in k -domain:

$$\check{\mathbf{V}}^{\text{out}}(\boldsymbol{\kappa}, z) = \check{\mathbf{V}}^{\text{in}}(\boldsymbol{\kappa}, z_0) \times \exp\left(i\check{k}_z(\boldsymbol{\kappa})\Delta z\right)$$

Field Tracing in Different Domains

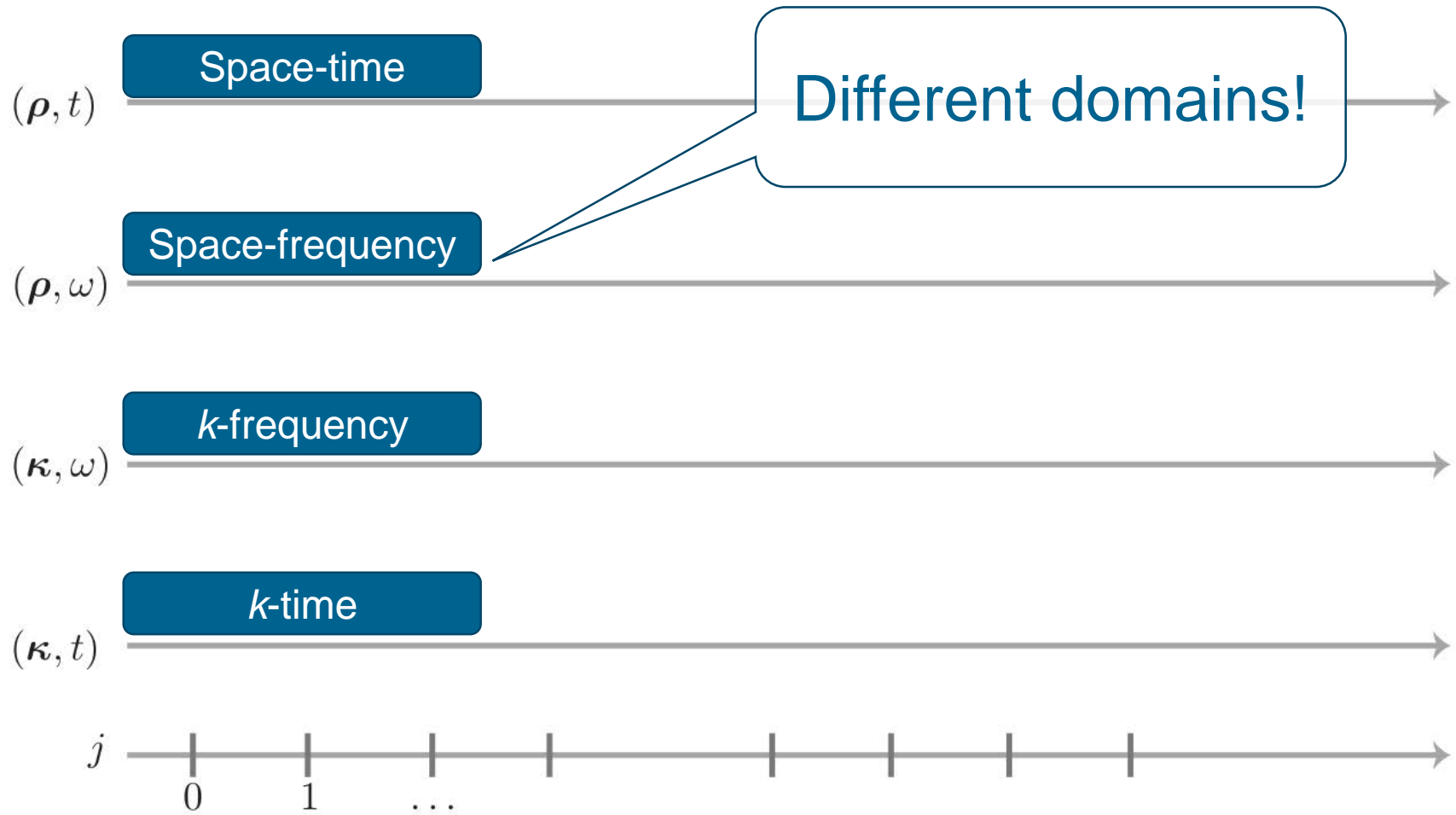

Field Tracing in Different Domains

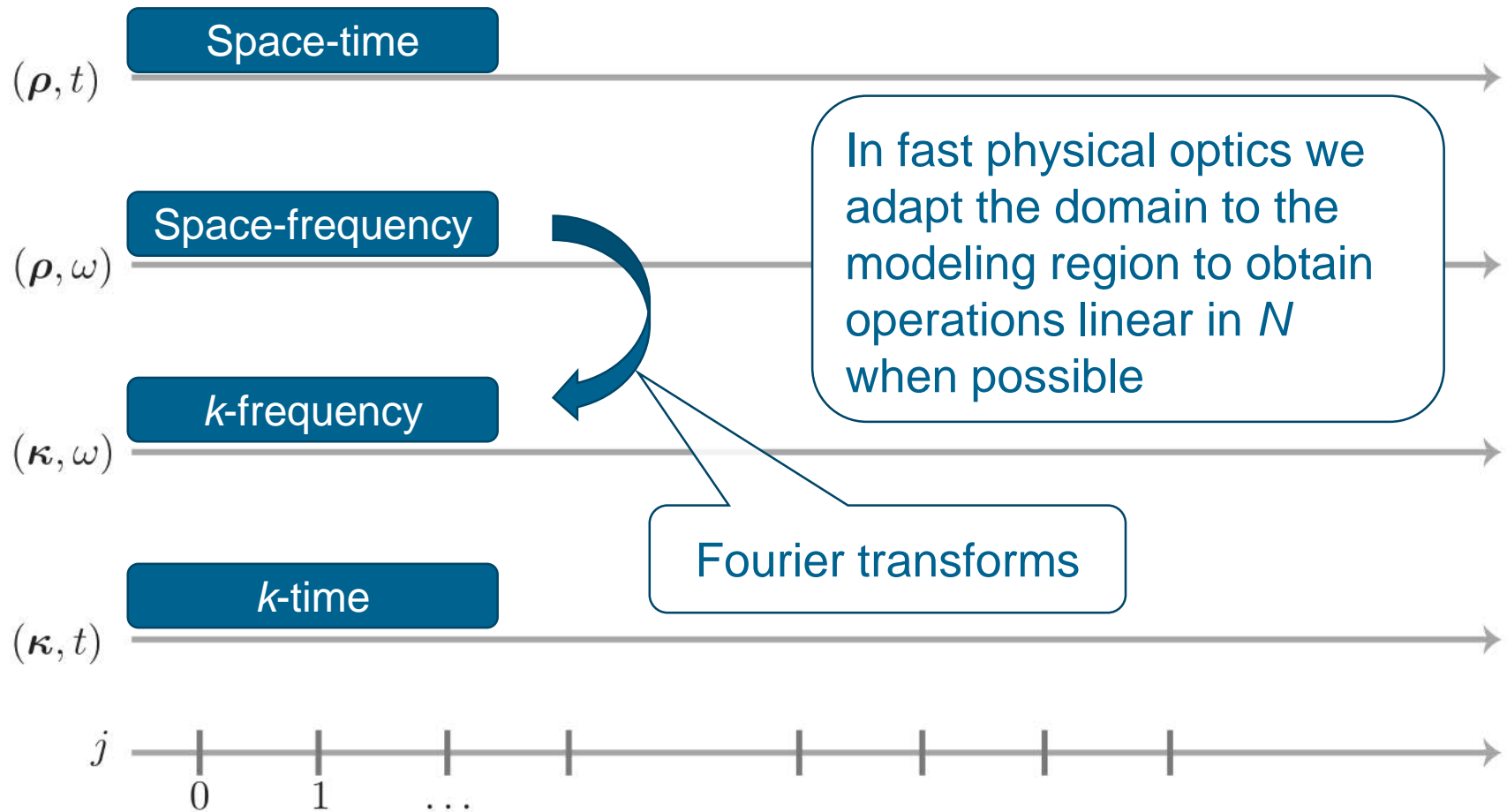

Fast Physical Optics by Field Tracing

- In fast physical optics we comply with the following
 1. Tearing: decomposed the whole optical system into regions and specialized Maxwell solvers are applied locally
 2. Interconnection: solutions in each regions are connected by the general non-sequential field tracing concept
 3. Field tracing operators should have numerical operation numbers linear with field sampling number N
 4. The field sampling number N should be minimized
 - Semi-analytical Fourier transform
Z. Wang *et al.*, „The semi-analytical fast Fourier transform,“ Proc. DGaO (2017)
 - Geometric Fourier transform
F. Wyrowski *et al.*, „The geometric Fourier transform,“ Proc. DGaO (2017)

Fourier transforms

Implementation

- All algorithms are implemented in the physical optics simulation and design software **VirtualLab Fusion**
- VirtualLab Fusion is developed, following the field tracing concept, by Wyrowski Photonics UG, Jena, Germany
- Visit German pavilion @**booth 4629-48** for more information

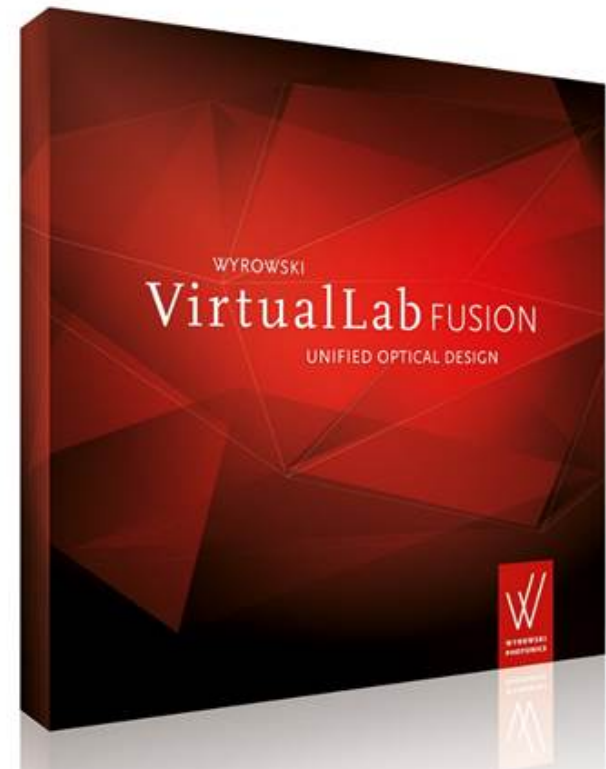

Example – Focusing Properties inside Crystal

- Many laser crystals are made out of birefringent materials whose optical properties depends strongly on the polarization of light and the orientation of the crystal

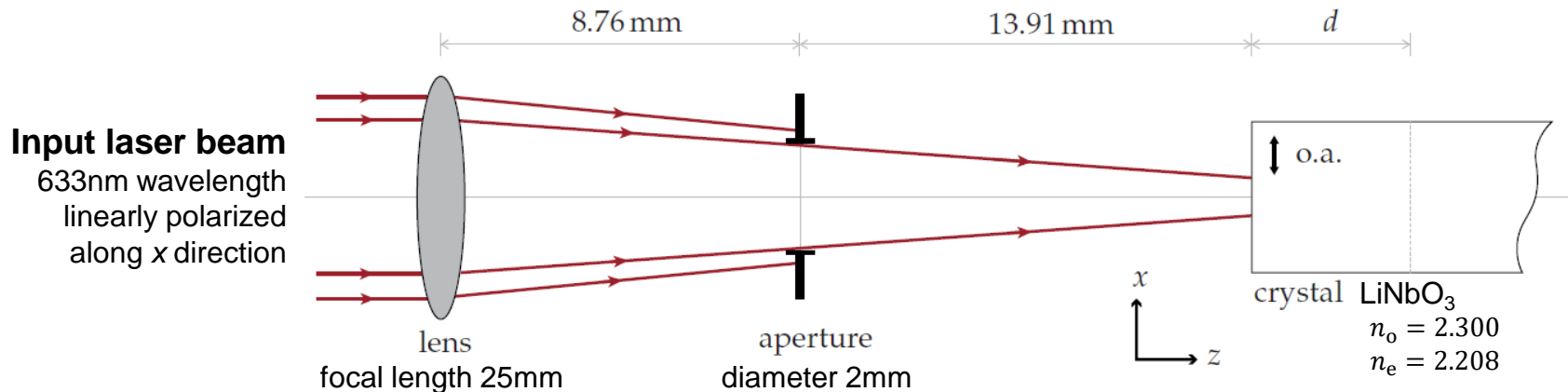

The optic axis of the crystal is first set along the x direction, then along the y direction

Field Tracing Diagram

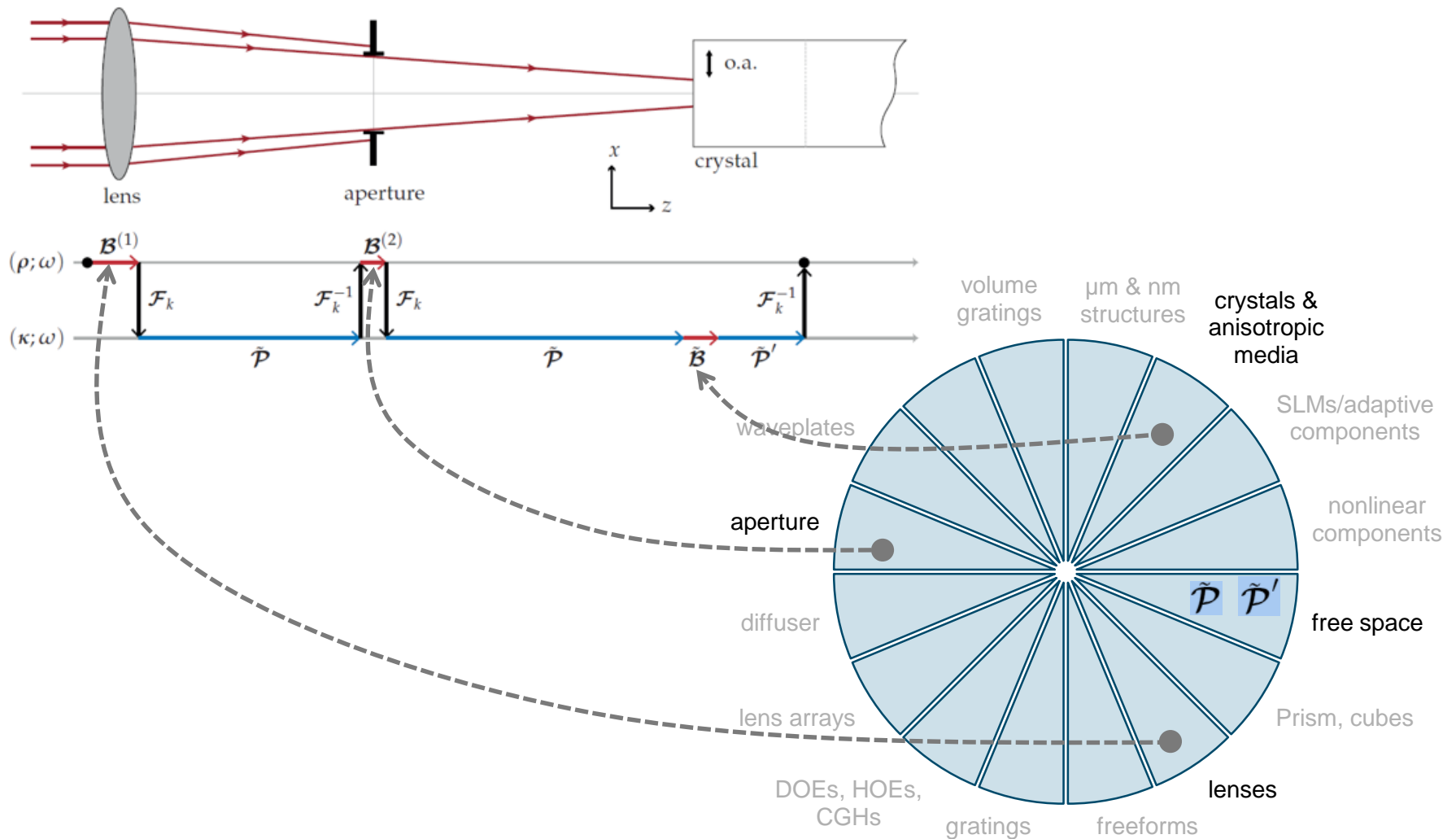

Simulation Results

- Light distribution at different depth (o.a. along y direction)

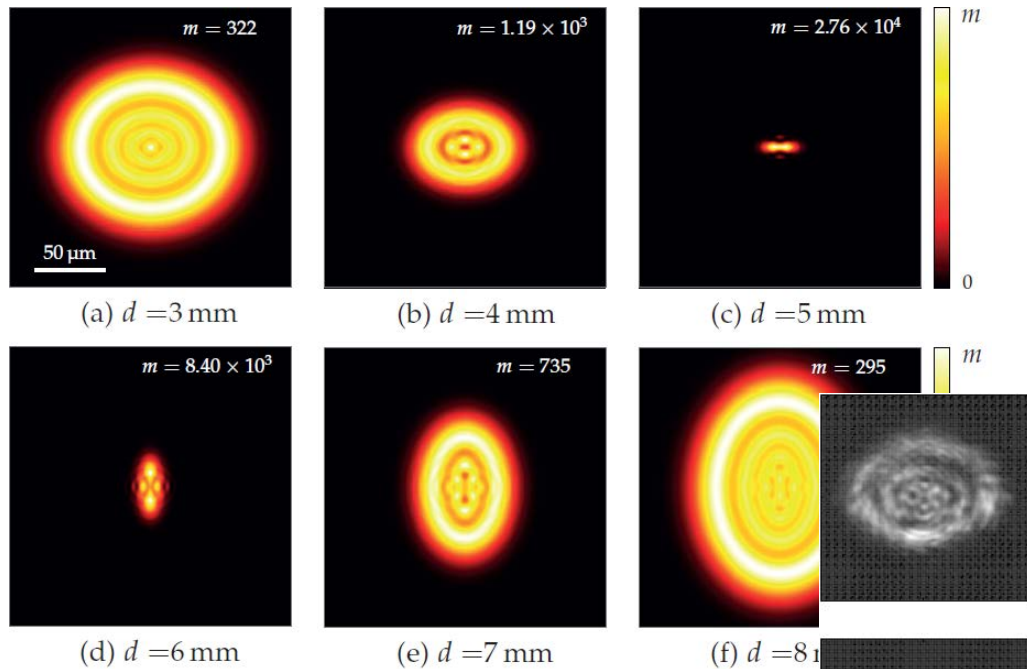

Calculation at one depth: ~ 9 s
with Intel Core i7-4910MQ

Experimental measurement

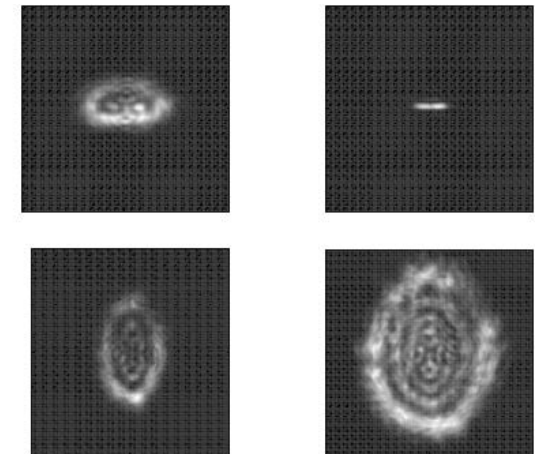

M. Jain et al., J. Opt. Soc. Am. A 26, 691-698 (2009)

Simulation Results

- Light distribution at different depth (o.a. along x direction)

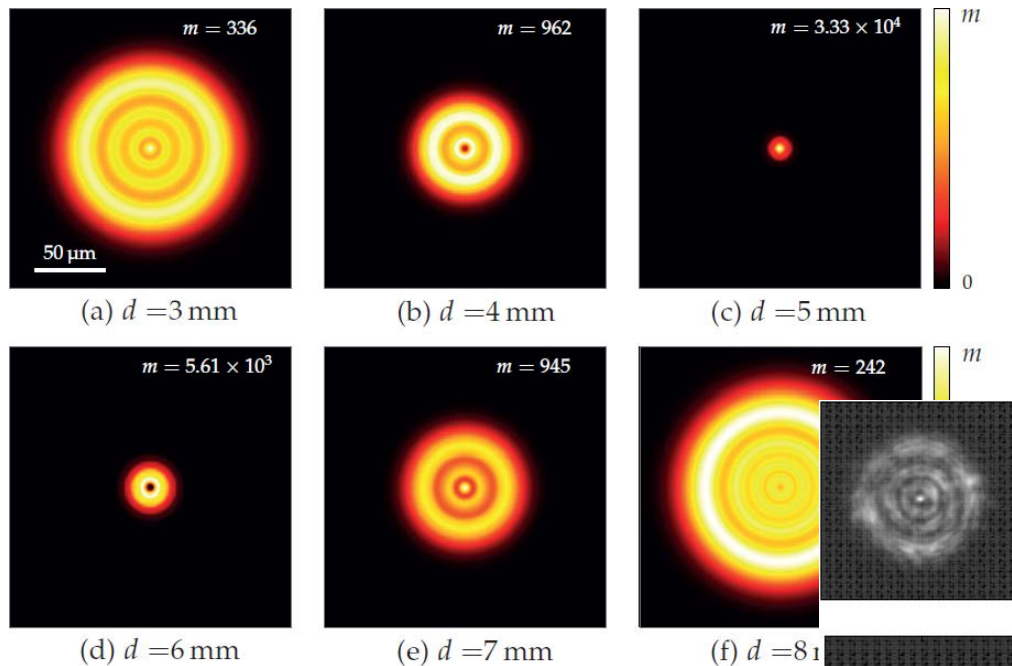

Experimental measurement

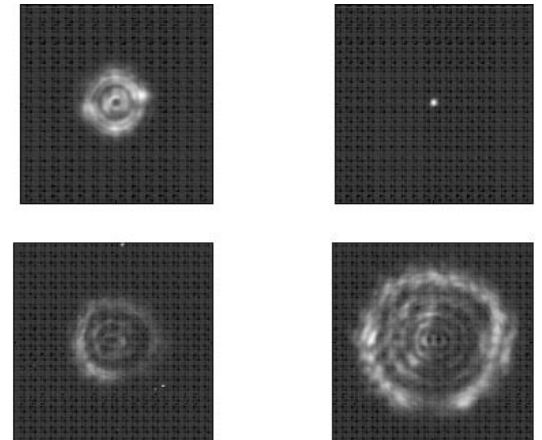

M. Jain et al., J. Opt. Soc. Am. A 26, 691-698 (2009)

Example – Stress Birefringence

- Laser-based soldering
 - Contact free heating, versatile to use
 - Localized and minimized input of energy
 - Flux-free processing, no contamination

P. Ribes-Pleguezuelo *et al.*, *Opt. Express* **25**, 5927-5940 (2017)



Photo from Fraunhofer IOF

- ANSYS
 - Structural/material definition
 - Transient thermal analysis
 - Stress simulation inside crystal component
- VirtualLab
 - Convert stress into optical permittivity data
 - Simulation of field propagation through birefringent materials

From Stress to Birefringence

- Convert stress to optical permittivity
(for each layer inside stratified medium)

Stress tensor

$$\begin{pmatrix} \sigma_1 & \sigma_6 & \sigma_5 \\ \sigma_6 & \sigma_2 & \sigma_4 \\ \sigma_5 & \sigma_4 & \sigma_3 \end{pmatrix}$$



Permittivity tensor

$$\begin{pmatrix} \epsilon_1 & \epsilon_6 & \epsilon_5 \\ \epsilon_6 & \epsilon_2 & \epsilon_4 \\ \epsilon_5 & \epsilon_4 & \epsilon_3 \end{pmatrix}$$

From Stress to Birefringence

- Convert stress to optical permittivity
(for each layer inside stratified medium)

Stress tensor

$$\begin{pmatrix} \sigma_1 & \sigma_6 & \sigma_5 \\ \sigma_6 & \sigma_2 & \sigma_4 \\ \sigma_5 & \sigma_4 & \sigma_3 \end{pmatrix}$$

↓

$$\Delta B_m = \pi_{mn} \sigma_n$$

↓

Piezo-optic constant

Changes in
impermeability tensor

$$\begin{pmatrix} \Delta B_1 & \Delta B_6 & \Delta B_5 \\ \Delta B_6 & \Delta B_2 & \Delta B_4 \\ \Delta B_5 & \Delta B_4 & \Delta B_3 \end{pmatrix}$$

From Stress to Birefringence

- Convert stress to optical permittivity
(for each layer inside stratified medium)

Stress tensor

$$\begin{pmatrix} \sigma_1 & \sigma_6 & \sigma_5 \\ \sigma_6 & \sigma_2 & \sigma_4 \\ \sigma_5 & \sigma_4 & \sigma_3 \end{pmatrix}$$

Piezo-optic constant

$$\Delta B_m = \pi_{mn} \sigma_n$$

Changes in impermeability tensor

$$\begin{pmatrix} \Delta B_1 & \Delta B_6 & \Delta B_5 \\ \Delta B_6 & \Delta B_2 & \Delta B_4 \\ \Delta B_5 & \Delta B_4 & \Delta B_3 \end{pmatrix}$$

Edit General Parameter: Double Array 2D

Array Dimension Specification
Number of Entries: 6 x 6
 Make Entries Available in Parameter Run

Array Index #0 ->

Array Index #1 ->	0	1	2	3	4
0	-1.21E-13	5.08E-14	5.08E-14	0	0
1	5.08E-14	-1.21E-13	5.08E-14	0	0
2	5.08E-14	5.08E-14	-1.21E-13	0	0
3	0	0	0	-5.38E-13	0
4	0	0	0	0	-5.38E-13
5	0	0	0	0	0

Reset Table Export / Import

OK Cancel Help

Example: piezo-optic constant tensor for YAG crystal

From Stress to Birefringence

- Convert stress to optical permittivity
(for each layer inside stratified medium)

Stress tensor

$$\begin{pmatrix} \sigma_1 & \sigma_6 & \sigma_5 \\ \sigma_6 & \sigma_2 & \sigma_4 \\ \sigma_5 & \sigma_4 & \sigma_3 \end{pmatrix}$$

↓ $\Delta B_m = \pi_{mn} \sigma_n$

Changes in
impermeability tensor

$$\begin{pmatrix} \Delta B_1 & \Delta B_6 & \Delta B_5 \\ \Delta B_6 & \Delta B_2 & \Delta B_4 \\ \Delta B_5 & \Delta B_4 & \Delta B_3 \end{pmatrix}$$

Impermeability tensor

$$\begin{pmatrix} B_1 & B_6 & B_5 \\ B_6 & B_2 & B_4 \\ B_5 & B_4 & B_3 \end{pmatrix}$$

$B_m = B_{0,m} + \Delta B_m$

Stress-free values
(related to refractive index/indices)

From Stress to Birefringence

- Convert stress to optical permittivity
(for each layer inside stratified medium)

Stress tensor

$$\begin{pmatrix} \sigma_1 & \sigma_6 & \sigma_5 \\ \sigma_6 & \sigma_2 & \sigma_4 \\ \sigma_5 & \sigma_4 & \sigma_3 \end{pmatrix}$$



$$\Delta B_m = \pi_{mn} \sigma_n$$

Changes in
impermeability tensor

$$\begin{pmatrix} \Delta B_1 & \Delta B_6 & \Delta B_5 \\ \Delta B_6 & \Delta B_2 & \Delta B_4 \\ \Delta B_5 & \Delta B_4 & \Delta B_3 \end{pmatrix}$$

$$B_m = B_{0,m} + \Delta B_m$$

Stress-free values
(related to refractive index/indices)

$$\begin{pmatrix} B_1 & B_6 & B_5 \\ B_6 & B_2 & B_4 \\ B_5 & B_4 & B_3 \end{pmatrix}$$

Example: ordinary refractive index for BBO crystal

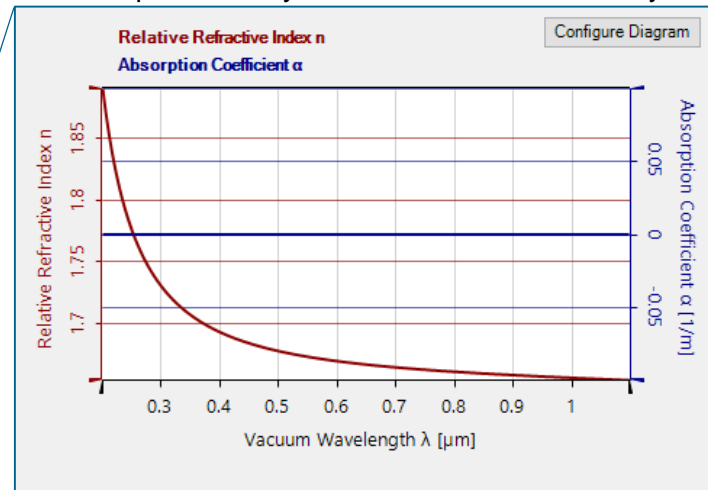

From Stress to Birefringence

- Convert stress to optical permittivity
(for each layer inside stratified medium)

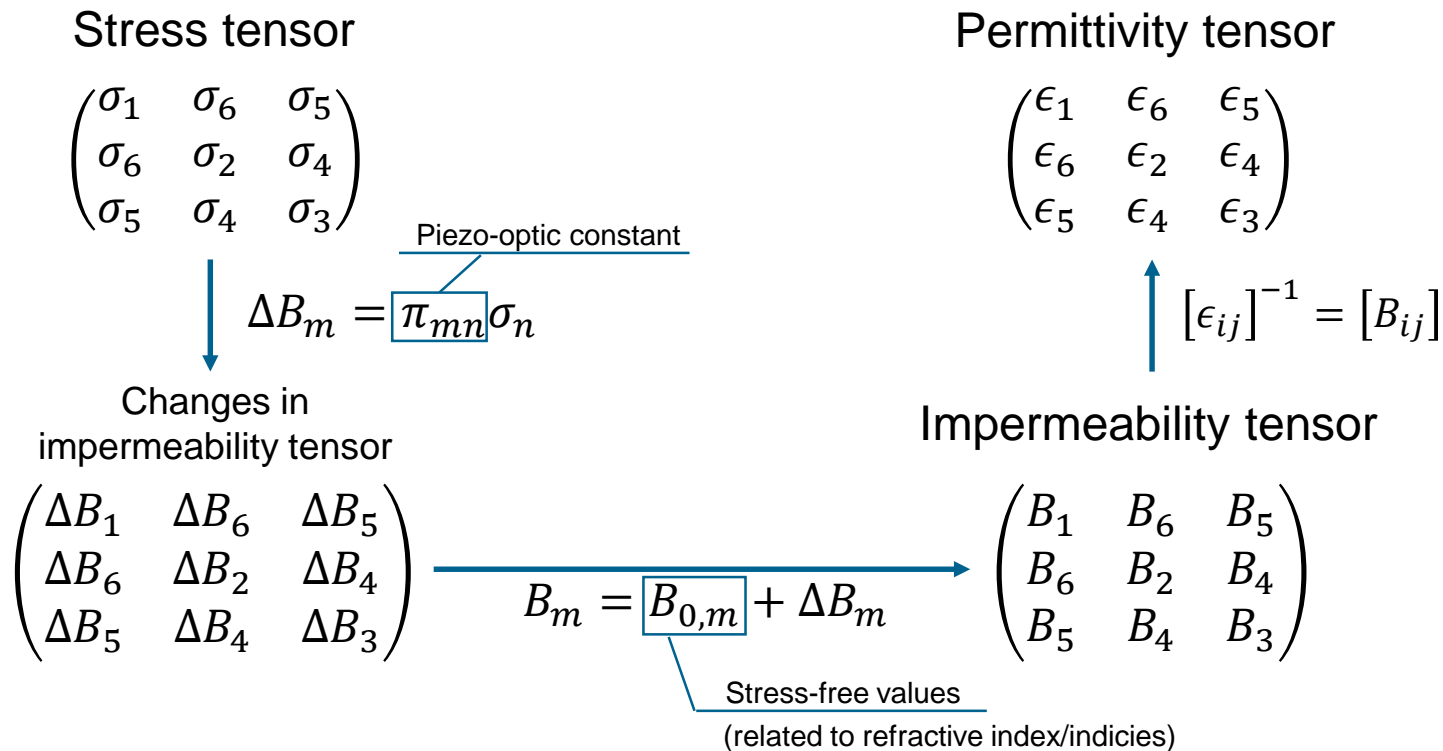

VirtualLab Simulation

- Convert stress to optical permittivity

```

Source Code Editor
Source Code Global Parameters Advanced Settings
Main Function
Snippet Body
5
6 /* Initialize the Harmonic Fields Set (HFS) for return
7 HarmonicFieldsSet hfsReturn = new HarmonicFieldsSet(Tr
8
9 /* Iteration through all member Harmonic Fields. */
10 for (int memberIndex = 0; memberIndex < hfsReturn.Sour
11 //Extraction of one single member Harmonic Field.
12 ComplexAmplitude currentMember = hfsReturn[member
13
14 #region stress data array, in lab system
15 // import 1D data arrays
16 dataArray2D stressData = new dataArray2D(imported:
17 PhysicalProperty.Pressure,
18 "Imported Stress Data",
19 sampDistanceZ,
20 0.0, // first coordinate
21 PhysicalProperty.Length,
22 "z",
23 1.0,
24 0.0, // first coordinate
25 PhysicalProperty.ArbitraryUnit,

```

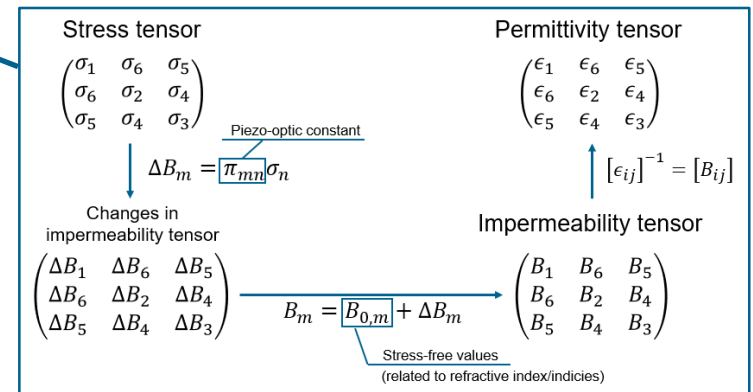

Conversion from stress tensor to the corresponding permittivity tensor is implemented by using the programmable component in VirtualLab

Simulation Results

- Input field

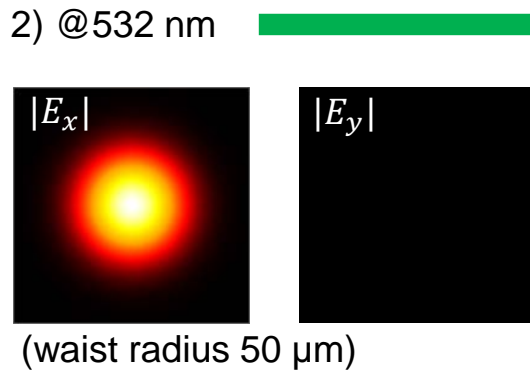
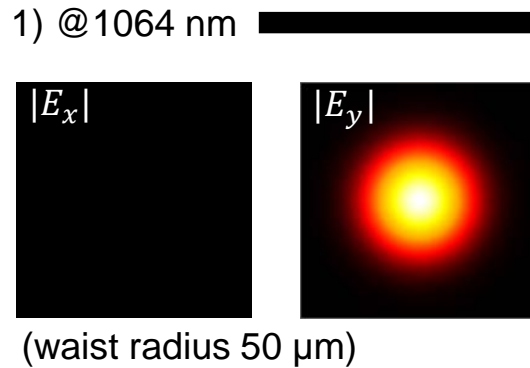

Note: we set the polarization according to the SHG configuration

- Applied stress

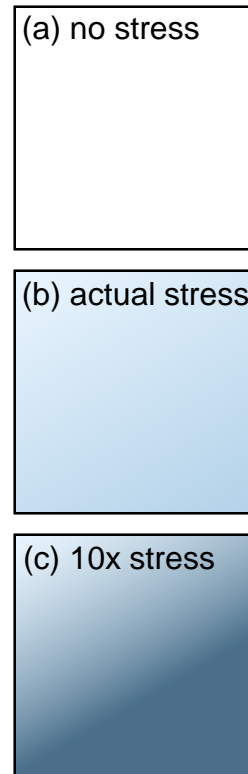

- Output field



Simulation Results

- YAG crystal with 1064 nm input field (E_y)

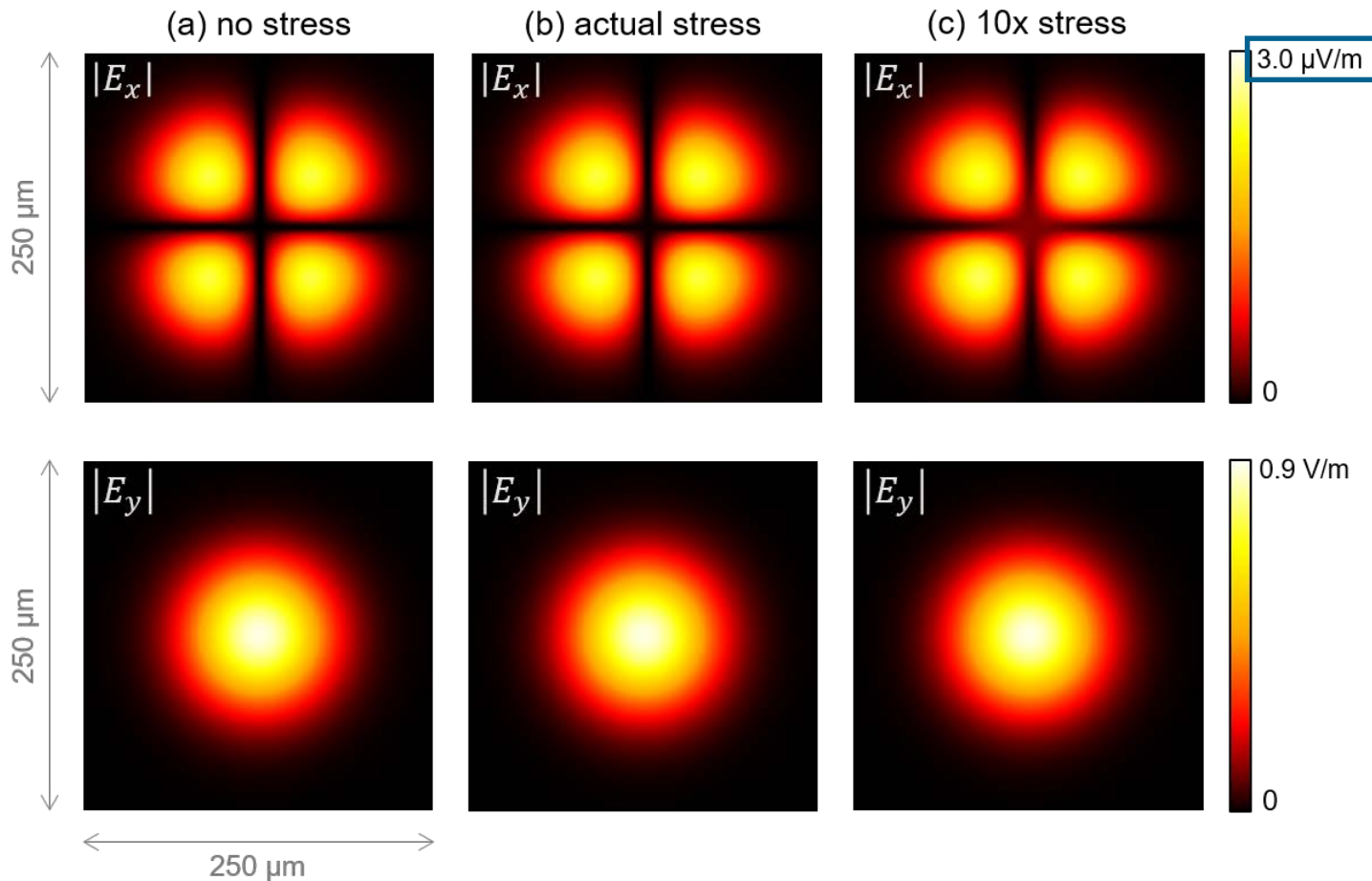

Simulation Results

- YAG crystal with 1064 nm input field (E_y)

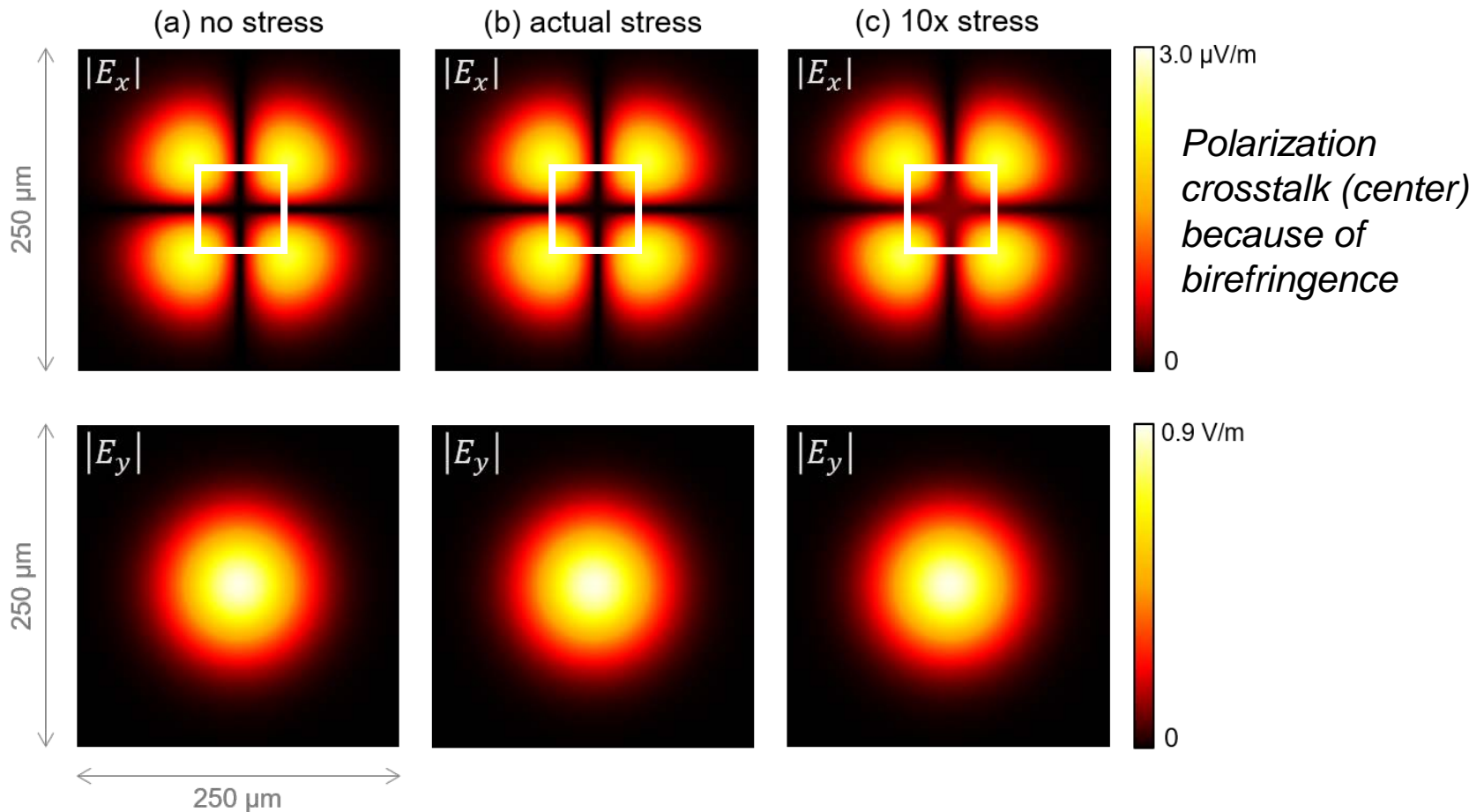

Simulation Results

- YAG crystal with 1064 nm input field (E_y)
 - Further check on the influence of stress-induced birefringence, we perform parameter run from 1x to 201x stresses (with 101 steps)

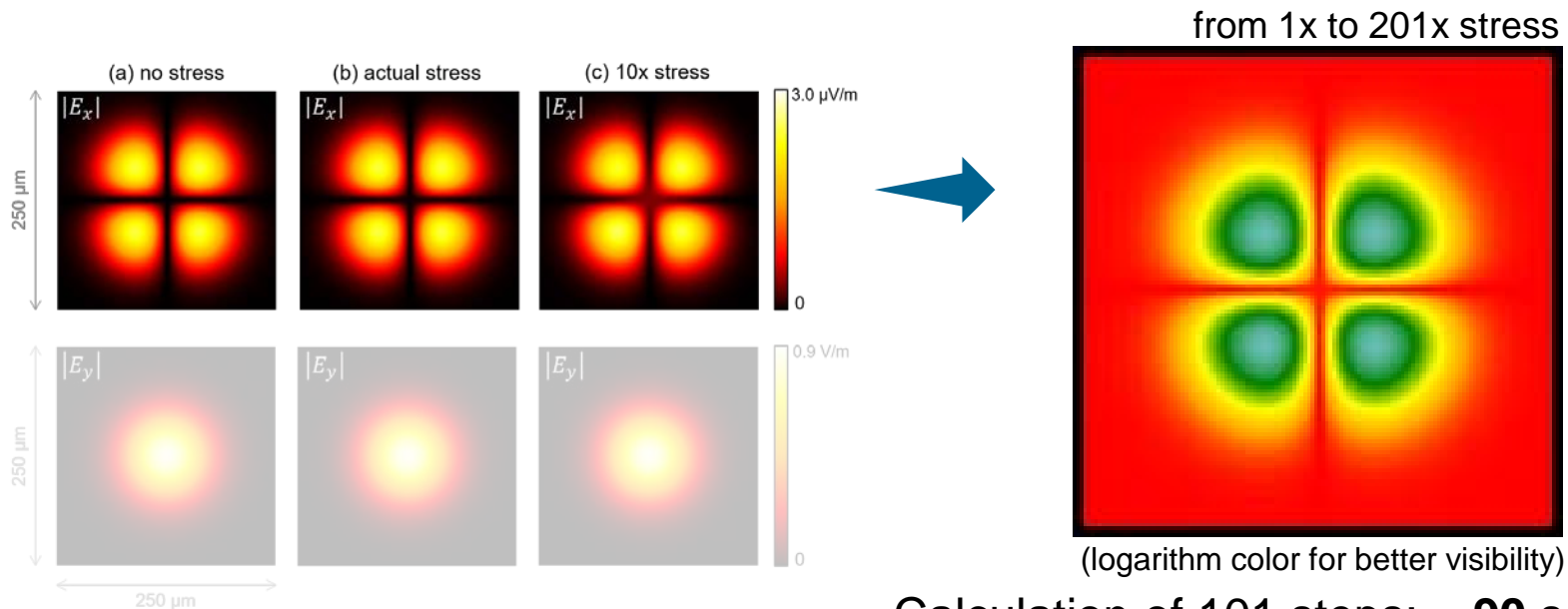

Calculation of 101 steps: ~ **90 s**
with Intel Core i7-4910MQ

Simulation Results

- YAG crystal with 532 nm input field (E_x)

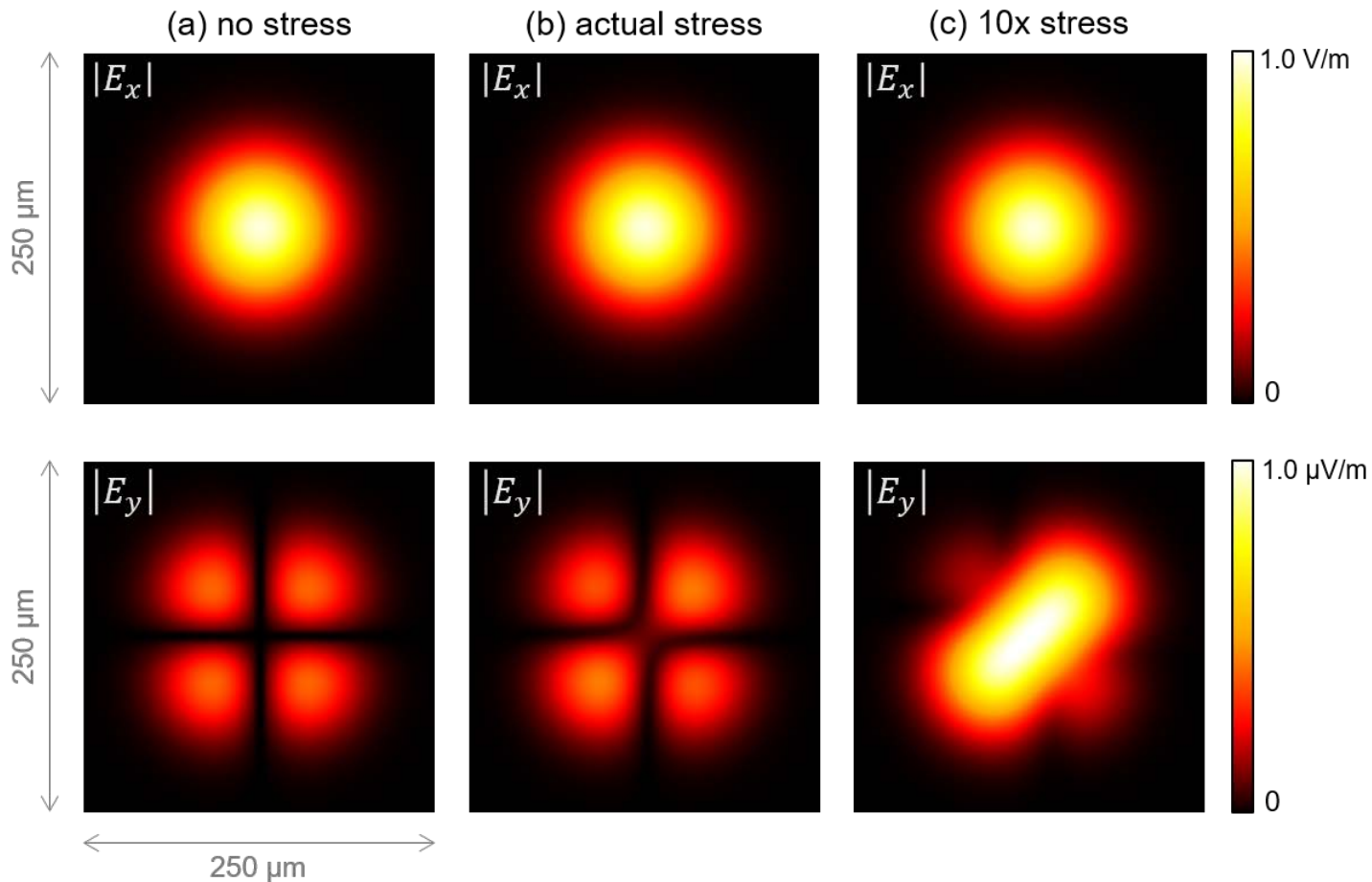

Simulation Results

- YAG crystal with 532 nm input field (E_x)
 - Further check on the influence of stress-induced birefringence, we perform parameter run from 1x to 51x stresses (with 101 steps)

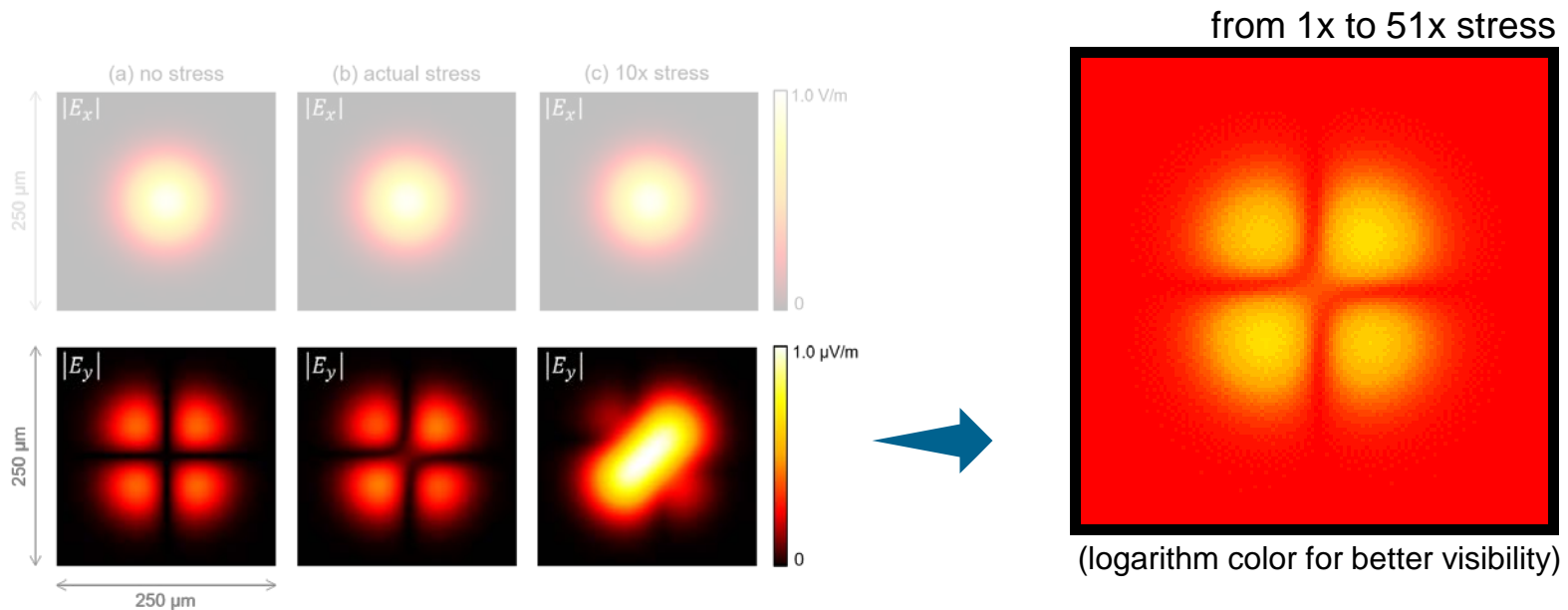

Example – Thermal Lens Effect

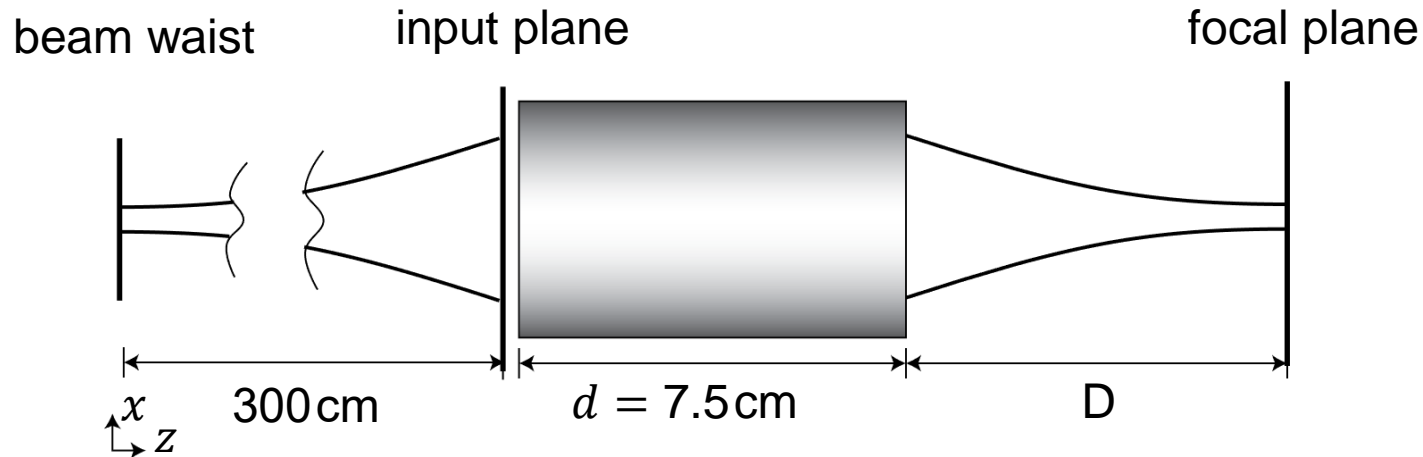

- simulation of a Gaussian beam focused by thermal lens effect induced by a high power laser.
- the refractive index $n(x, y)$ of the thermal lens changes with varying input power.

Specifications: Light Source

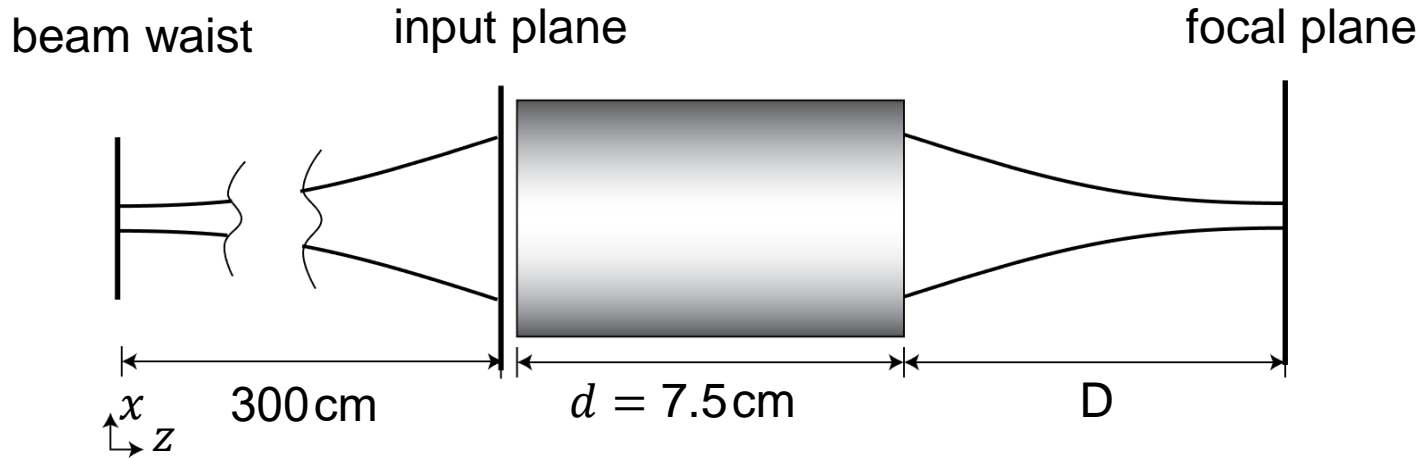

Parameter	Description / Value
coherence/mode	single Laguerre Gaussian (0,0) and (1,0) mode
wavelength	632.8 nm
polarization	linear in x-direction (0°)
beam waist radius	simulation 1: (0,0) mode: $760 \mu\text{m}$ simulation 2: (1,0) mode: 1 mm

Specifications: Thermal Lens

- Refractive index is

$$n(x, y) = n_0 - \frac{\eta P_{\text{in}}}{4K\pi d} \cdot \frac{\delta n}{\delta T} \cdot \frac{r^2}{r_0^2}$$

with $r = \sqrt{x^2 + y^2}$, r_0 and d are shown in the figure, P_{in} is input power, K , η and $\frac{\delta n}{\delta T}$ are temperature-related parameters which can be found in [1]

- Here the values are

- $r_0 = 0.31\text{cm}$, $d = 7.5\text{cm}$

- $K = 11.1\text{ W}/(\text{cm}^\circ\text{C})$, $\eta = 0.05$, $\frac{\delta n}{\delta T} = 7.3 \times 10^{-6}\text{ }^\circ\text{C}^{-1}$

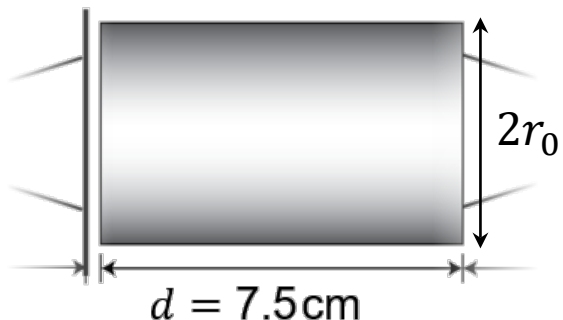

Highlight

arbitrarily customizable
refractive index profile

Specifications: Detector

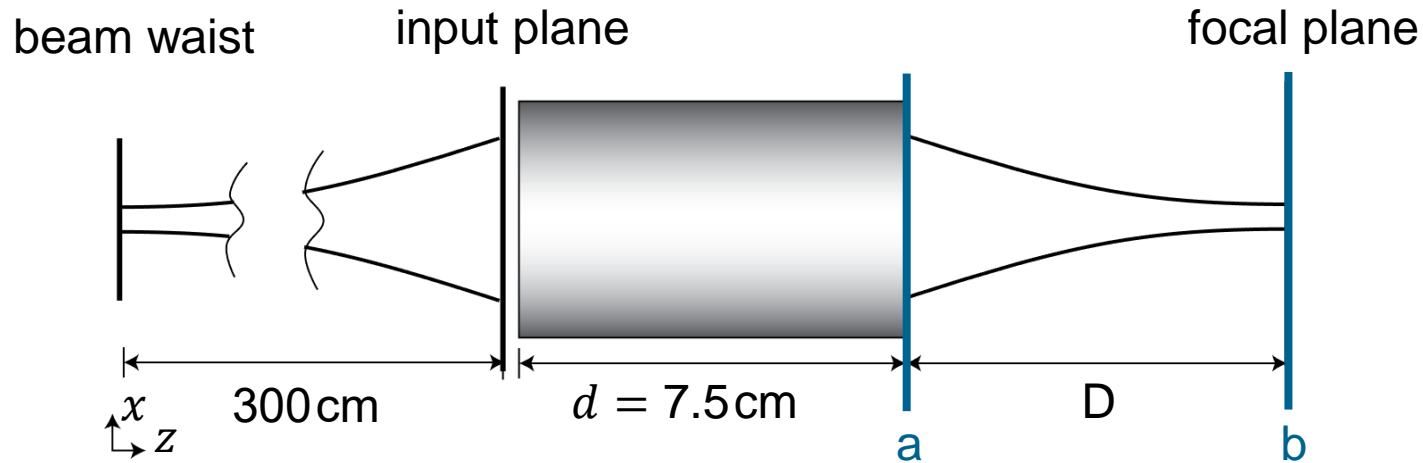

Position	Modeling Technique	Detector/Analyzer
a	field tracing	beam parameters for different input beams and input power values
b	field tracing	amplitude of E_x, E_y, E_z when input is (1,0) mode

Results: (0,0) Mode

- Using the *Parameter Run* document, one can calculate the output beam parameters for input powers varying from 8kW to 20kW. The detector is at position a .
 - Absolute value of *Waist Distance* (distance a with respect to b) is distance D .
 - Waist Diameter* is the waist diameter in focal plane (position b).

11: Parameter Run from 1: Light Path Editor (C:\Users\...\Example2.lpd #1)*

Results
Start the parameter run and analyze its results

Go!

Use Cached Results for Next Run

Detector	Subdetector	Combined Output	Iteration Step			
			1	2	3	4
Varied Parameters	P (Double Interface Compo...	Data Array	8 kW	9 kW	10 kW	11 kW
Beam Parameters #607 after Double Interface Component #1 (T) (Field Tracing 2nd Generation)	Waist Diameter X	Data Array	90.41921264 μm	80.34617646 μm	72.38992882 μm	65.57255852 μm
	Waist Diameter Y	Data Array	90.39943671 μm	80.36018607 μm	72.41032871 μm	65.56938795 μm
	Waist Distance X	Data Array	-225.3013984 mm	-197.8086613 mm	-175.972568 mm	-158.2061152 mm
	Waist Distance Y	Data Array	-225.3018184 mm	-197.8093367 mm	-175.9720342 mm	-158.2064622 mm

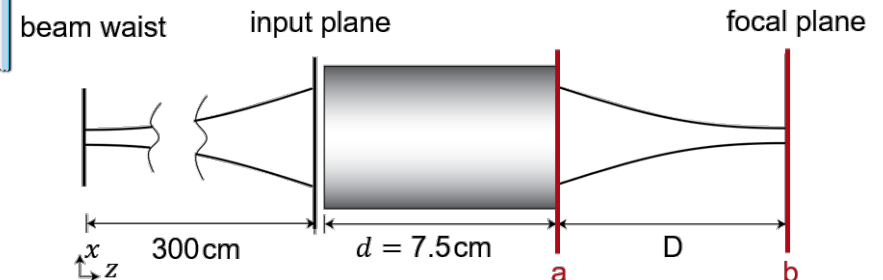

Results: (0,0) Mode

11: Parameter Run from 1: Light Path Editor (C:\Users\...\Example2.lpd #1)*

Results
Start the parameter run and analyze its results

Go!

Use Cached Results for Next Run

Detector	Subdetector	Combined Output	Iteration Step			
			1	2	3	4
Variied Parameters	P (Double Interface Compo...	Data Array	8 kW	9 kW	10 kW	11 kW
Beam Parameters #607 after Double Interface Component #1 (T) (Field Tracing 2nd Generation)	Waist Diameter X	Data Array	90.41921264 μm	80.34617646 μm	72.38992882 μm	65.57255852 μm
	Waist Diameter Y	Data Array	90.39943671 μm	80.36018607 μm	72.41032871 μm	65.56938795 μm
	Waist Distance X	Data Array	-225.3013984 mm	-197.8096613 mm	-175.972568 mm	-158.2061152 mm
	Waist Distance Y	Data Array	-225.3018184 mm	-197.8093367 mm	-175.9720342 mm	-158.2064622 mm

Highlight

simulate conveniently one system with varying parameters

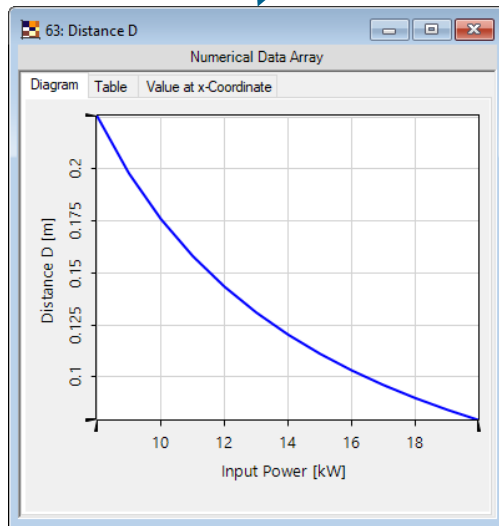

distance D

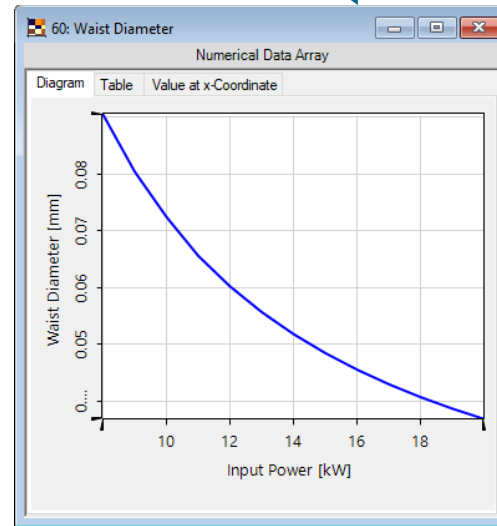

waist diameter at b

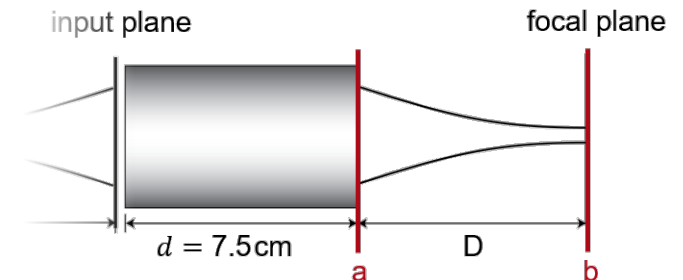

Results: (1,0) Mode

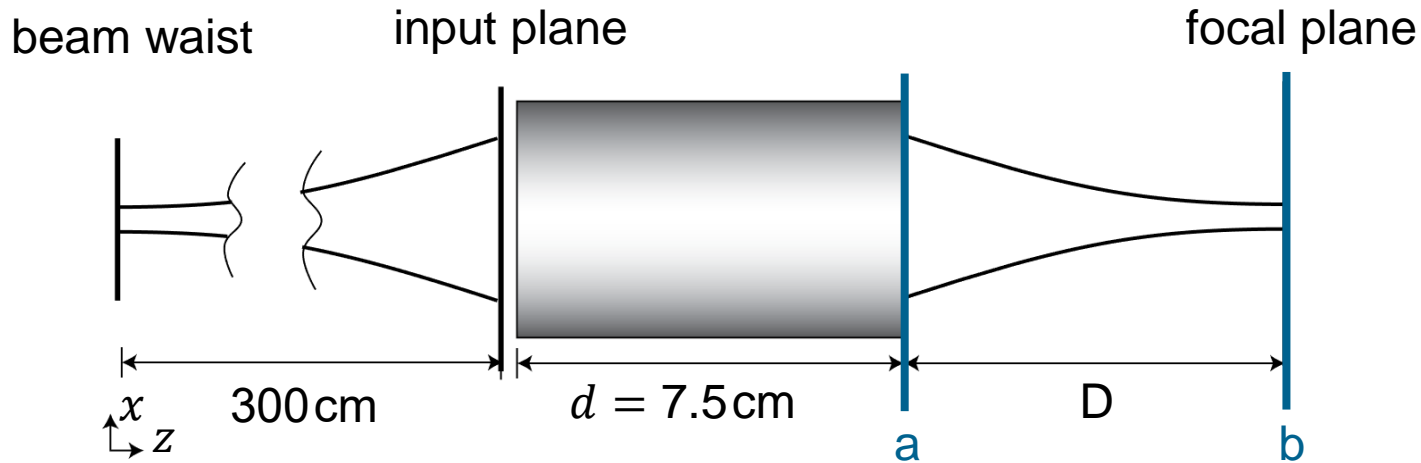

- For the thermal lens with applied 18kW the simulated distance D is 91.0mm.
- The technique to propagate fields through the thermal lens is described in [2].
- The technique to propagate fields from position a to b is diffractive propagation integral [3].

Results: (1,0) Mode

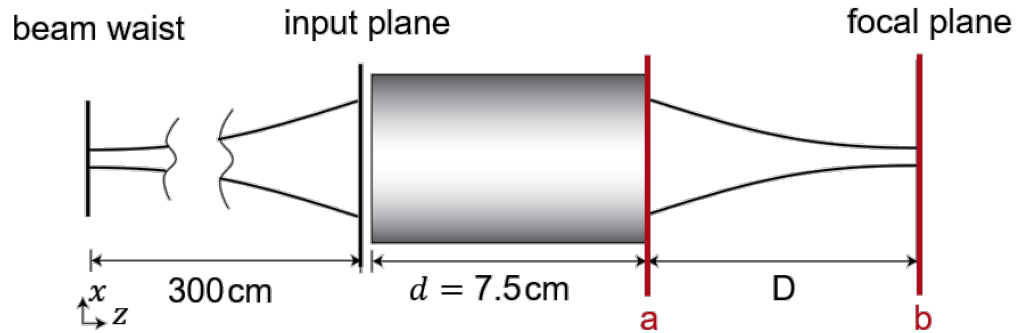

Highlight

combination of different field tracing techniques

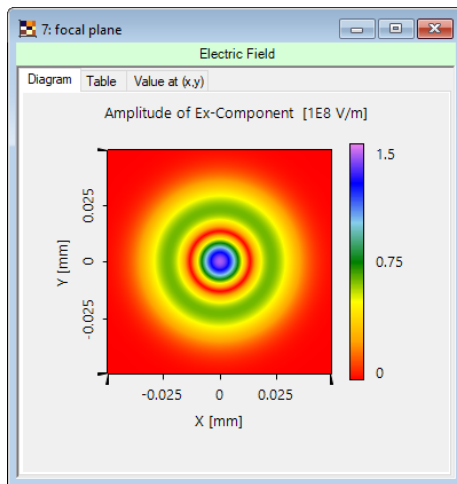

E_x

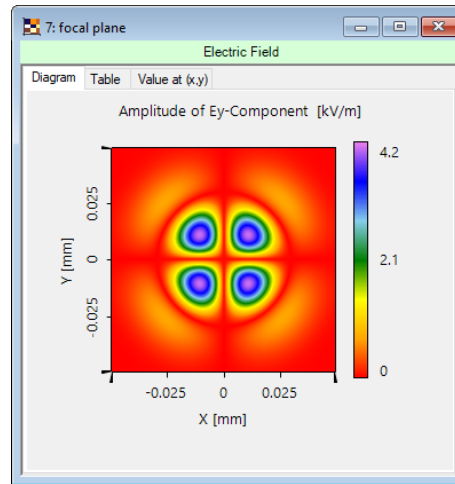

E_y

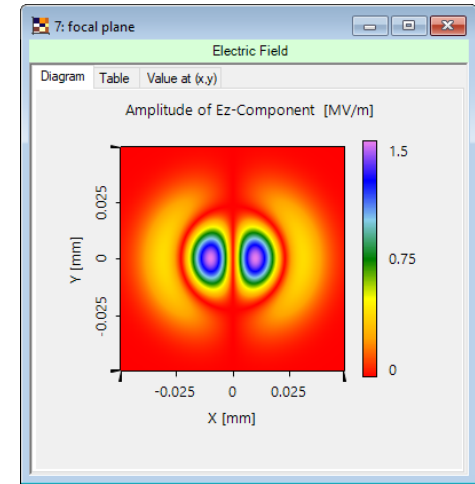

E_z

Summary

We provide a platform for fast Maxwell Solvers!

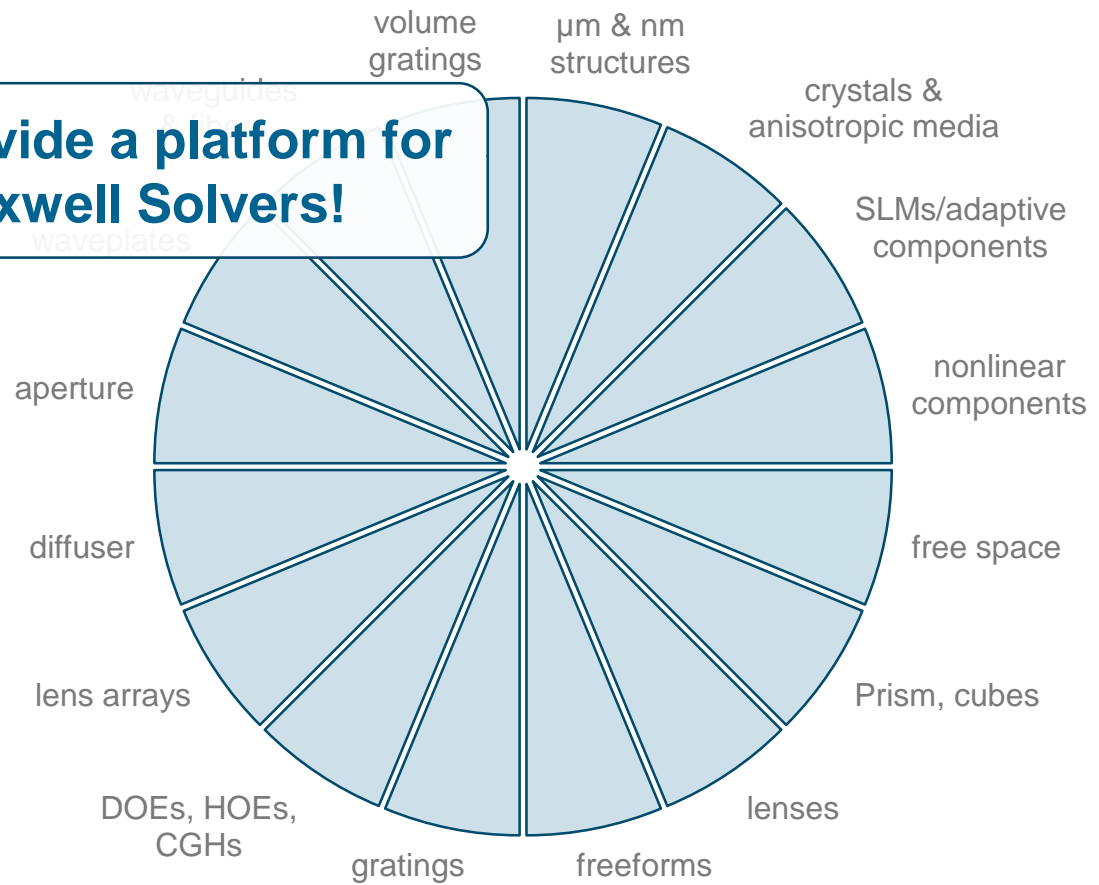

Announcement

- **„Fast propagation of electromagnetic field through graded-index media“**, H. Zhong *et al.*, 30 January 2018, 3:05 – 3:25 PM
- **„Non-paraxial diffractive and refractive laser beam shaping“**, L. Yang *et al.*, 1 February 2018, 2:25 – 2:45 PM

Free Optical Design Seminar

- **„Analysis and Design of Diffractive and Micro-Optical Systems with VirtualLab Fusion“**
2 February 2018, 09:30 – 16:15